

Systems

# fermacell® CLT/X-LAM Building in Timber

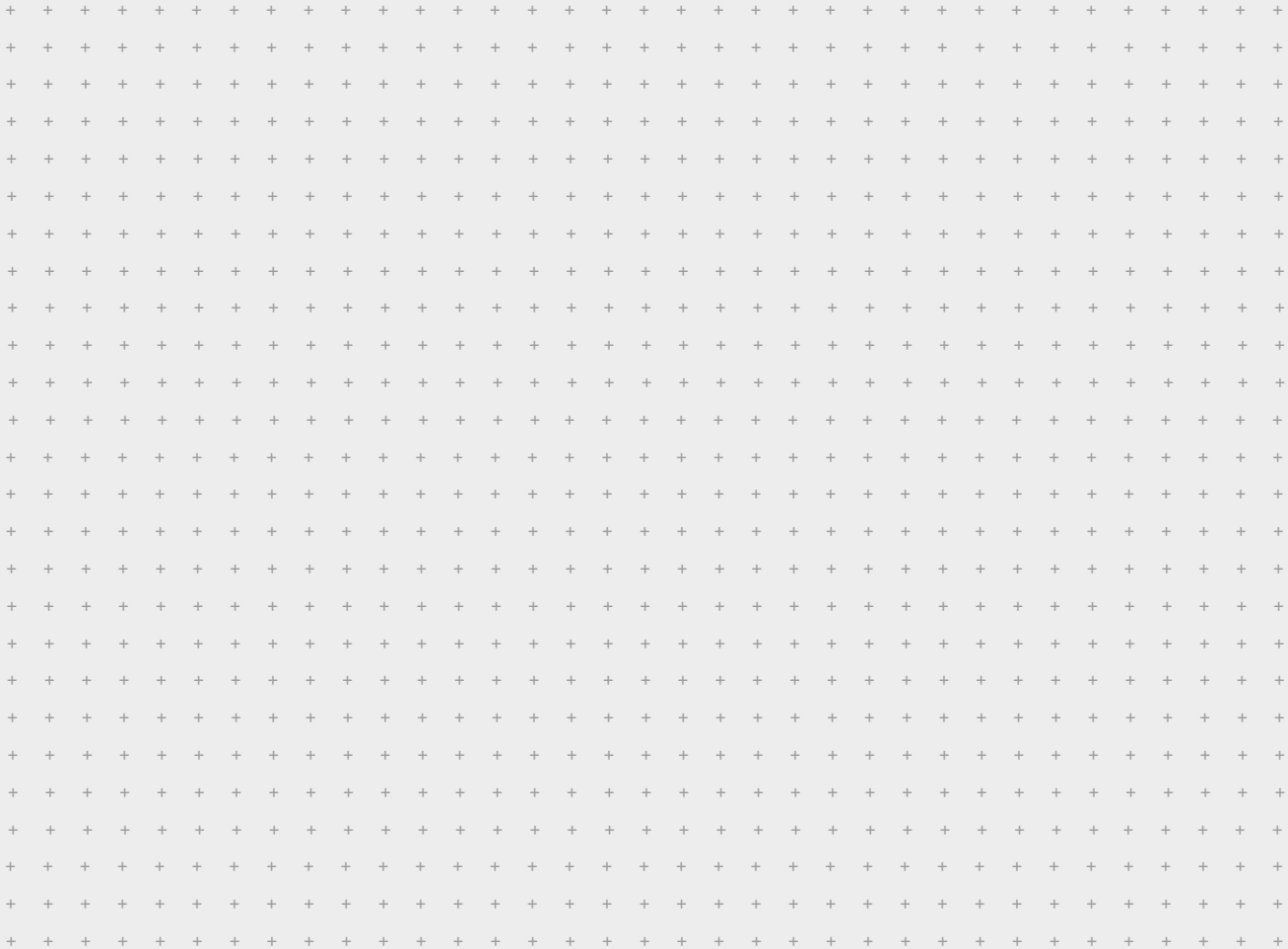

# 1. Wall

## 1.1 CLT/X-LAM

fermacell®

System-Specification	Systemdrawing	Wall Thickness	CLT / X-LAM	Facings	Insulation Thickness/Density
		[mm]	[mm]	[mm]	[mm]/[kg/m³]
1 HTM 11		≥ 100	≥ 80	10	-
1 HTM 23		≥ 100	≥ 80	10	-
1 HTM 24		≥ 130	≥ 80	2×12,5	-
1 HTM 21		≥ 145	≥ 120	12,5	-
1 HTM 22		≥ 172	≥ 120	12,5 one side traverse -resilent bar	Glass-wool
1 HTM 34		≥ 130	≥ 80	2×12,5	-
1 HTM 32		≥ 145	≥ 120	12,5	-
1 HTM 33		≥ 172	≥ 120	12,5 one side traverse -resilent bar	Glass-wool
1 HTM 31		≥ 180	≥ 120	2×15	-
1 HTM 41		≥ 156	≥ 120	18	-
1 HTM 42		≥ 180	≥ 120	2×15	-

\* arithmetically acc. Soundinsulationsoftware NSUL, Version v.8.0.3

\*\* based on EN 13501-2

Applied Load	Wall Weight	Sound Insulation	Sound Insulation	Fire Rating according EN 13501-2 (EN 1365-1)	Classification Report
[kN/m]	[kg/m <sup>2</sup> ]	R <sub>w</sub> [dB]	D <sub>n,f,W</sub> <sup>(12)</sup> [dB]		
160	≥ 60	R <sub>w</sub> ≥ 37 [-1;-3]* Pb.- Nr.: 04-001031	-	REI30	KB 3.2/19-354-3 -Covering: K <sub>2</sub> 10 -PC10069 -T <sub>max. 10 minutes</sub> : 112 °C
40	≥ 60	R <sub>w</sub> ≥ 37 [-1;-3]* Pb.- Nr.: 04-001030	-	REI60	KB 3.2/19-354-3 -Covering: K <sub>2</sub> 10 -PC10069 -T <sub>max. 10 minutes</sub> : 112 °C
160	≥ 96	R <sub>w</sub> ≥ 41 [-1;-3]* Pb.- Nr.: 04-001029	-	REI60	KB 3.2/19-354-4 -Covering: K <sub>2</sub> 30 -PCA10402A -T <sub>max. 30 minutes</sub> : 115 °C
200	≥ 87	≥ 40 [-1;-3]* Pb.- Nr.: 04-001028	-	REI60	KB 3.2/16-279-3 -Covering: K <sub>2</sub> 10 -PC10069 -T <sub>max. 10 minutes</sub> : 112 °C
200	≥ 89	R <sub>w</sub> ≥ 53 [-4;-11]* Pb.- Nr.: 04-001027	-	REI60	KB 3.2/16-388-2 -Covering: K <sub>2</sub> 10 -PC10069 -T <sub>max. 10 minutes</sub> : 112 °C
40	≥ 96	R <sub>w</sub> ≥ 41 [-1;-3]* Pb.- Nr.: 04-001026	-	REI90	KB 3.2/19-354-4 -Covering: K <sub>2</sub> 30 -PCA10402A -T <sub>max. 30 minutes</sub> : 115 °C
120	≥ 87	≥ 40 [-1;-3]* Pb.- Nr.: 04-001024	-	REI90	KB 3.2/16-279-3 -Covering: K <sub>2</sub> 10 -PC10069 -T <sub>max. 10 minutes</sub> : 112 °C
120	≥ 89	R <sub>w</sub> ≥ 53 [-4;-11]* Pb.- Nr.: 04-01023	-	REI90	KB 3.2/16-388-2 -Covering: K <sub>2</sub> 10 -PC10069 -T <sub>max. 10 minutes</sub> : 112 °C
200	≥ 129	≥ 44 [-1;-3]* Pb.- Nr.: 04-001021	-	REI90	KB 3.2/15-369-4 (Covering: K <sub>2</sub> 45)**
120	≥ 100	≥ 41 [-1;-2]* Pb.- Nr.: 04-001022	-	REI120	KB 3.2/15-369-3 -Covering: K <sub>2</sub> 30 -PCA10168 -T <sub>max. 30 minutes</sub> : 153 °C
150	≥ 129	≥ 44 [-1;-32]* Pb.- Nr.: 04-001021	-	REI120	KB 3.2/15-369-4 (Covering: K <sub>2</sub> 45)**

# 1. Wall

## 1.1 CLT/X-LAM

### Firepanel A1

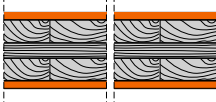
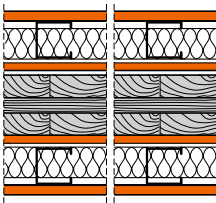
System Specification	Systemdrawing	Wall Thickness	CLT / X-LAM	Facings	Insulation Thickness/Density
		[mm]	[mm]	[mm]	[mm]/[kg/m <sup>3</sup> ]
1 HTM 21 A1		≥ 100	≥ 80 mm	10	-
1 HTM 41 A1		≥ 235	≥ 80 mm	12,5 (CW50) 10	40/40

### fermacell® - cavity wall

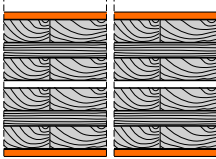
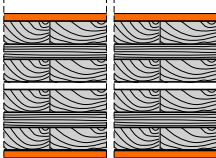
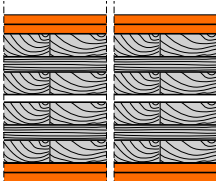
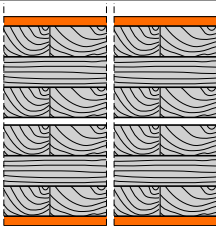
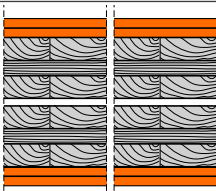
System Specification	Systemdrawing	Wall Thickness	CLT / X-LAM	Facings	Insulation Thickness/Density
		[mm]	[mm]	[mm]	[mm]/[kg/m <sup>3</sup> ]
1 HTM 12		≥ 190	≥ 2 × 80 mm  10 mm cavity  100 mm cavity	10	-  80/10
1 HTM 25		≥ 190	≥ 2 × 80 mm  10 mm cavity  100 mm cavity	10	-  80/10
1 HTM 26		≥ 220	≥ 2 × 80 mm  10 mm cavity  100 mm cavity	2 × 12,5	-  80/18
1 HTM 27		≥ 275	≥ 2 × 120 mm  10 mm cavity  100 mm cavity	12,5	-  80/10
1 HTM 35		≥ 220	≥ 2 × 80 mm  10 mm cavity  100 mm cavity	2 × 12,5	-  80/18

Applied Load	Wall Weight	Sound Insulation $R_w$	Sound Insulation $D_{n,f,W}^{(12)}$	Fire Rating according EN 13501-2 (EN 1365-1)	Classification Report
[kN/m]	[kg/m <sup>2</sup> ]	[dB]	[dB]		
45	≥ 61	$R_w \geq 37$ [-1;-3]* Pb.- Nr.: 04-01020	-	REI60	N° CSI1958FR -Covering: K <sub>2</sub> 10 -PCA10080 -T <sub>max. 10 minutes</sub> : 135 °C
45	≥ 95	$R_w \geq 71$ [-6;-14]* Pb.- Nr.: 04-01019	-	REI120	N° CSI1959FR

Applied Load	Wall Weight	Sound Insulation $R_w$	Sound Insulation $D_{n,f,W}^{(12)}$	Fire Rating according EN 13501-2 (EN 1365-1)	Classification Report
[kN/m]	[kg/m <sup>2</sup> ]	[dB]	[dB]		
160 each wall side	≥ 96	$R_w \geq 49$ [-3;-11]* Pb.- Nr.: 04-01017 <hr/> $R_w \geq 69$ [-2;-6]* Pb.- Nr.: 04-01018	-	REI30	KB 3.2/19-354-3 -Covering: K <sub>2</sub> 10 -PC10069 -T <sub>max. 10 minutes</sub> : 112 °C
40 each wall side	≥ 96	$R_w \geq 49$ [-3;-9]* Pb.- Nr.: 04-01015 <hr/> $R_w \geq 69$ [-2;-6]* Pb.- Nr.: 04-01016	-	REI60	KB 3.2/19-354-3 -Covering: K <sub>2</sub> 10 -PC10069 -T <sub>max. 10 minutes</sub> : 112 °C
160 each wall side	≥ 132	$R_w \geq 54$ [-3;-11]* Pb.- Nr.: 04-01014 <hr/> $R_w \geq 74,5$ [-2;-4] Pb.- Nr.: 04-00961	-	REI60	KB 3.2/19-354-4 -Covering: K <sub>2</sub> 30 -PCA10402A -T <sub>max. 30 minutes</sub> : 115 °C
200 each wall side	≥ 143	$R_w \geq 55$ [-5;-12]* Pb.- Nr.: 04-01012 <hr/> $R_w \geq 75$ [-2;-6]* Pb.- Nr.: 04-01013	-	REI60	KB 3.2/16-279-3 -Covering: K <sub>2</sub> 10 -PC10069 -T <sub>max. 10 minutes</sub> : 112 °C
40 each wall side	≥ 132	$R_w \geq 54$ [-4;-11]* Pb.- Nr.: 04-01011 <hr/> $R_w \geq 74,5$ [-2;-4] Pb.- Nr.: 04-0961	-	REI90	KB 3.2/19-354-4 -Covering: K <sub>2</sub> 30 -PCA10402A -T <sub>max. 30 minutes</sub> : 115 °C

# 1. Wall

## 1.1 CLT/X-LAM

### fermacell® - cavity wall

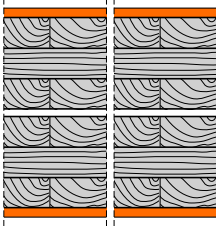
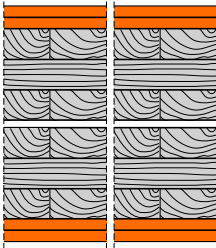
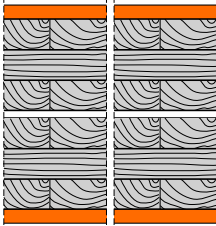
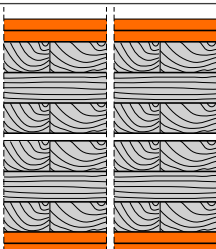
System Specification	Systemdrawing	Wall Thickness	CLT / X-LAM	Facings	Insulation Thickness/Density
		[mm]	[mm]	[mm]	[mm]/[kg/m <sup>3</sup> ]
1 HTM 36		≥ 275	≥ 2 × 120 mm 10 mm cavity 100 mm cavity	12,5	- 80/10
1 HTM 37		≥ 310	≥ 2 × 120 mm 10 mm cavity 100 mm cavity	2×15	- 80/18
1 HTM 43		≥ 286	≥ 2 × 120 mm 10 mm cavity 100 mm cavity	18	- 80/18
1 HTM 44		≥ 310	≥ 2 × 120 mm 10 mm cavity 100 mm cavity	2×15	- 80/18

\*arithmetically acc. Soundinsulationsoftware INSUL, Version v.8.0.3

### Firepanel A1 - cavity wall

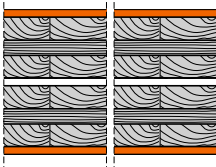
System Specification	Systemdrawing	Wall Thickness	CLT / X-LAM	Facings	Insulation Thickness/Density
		[mm]	[mm]	[mm]	[mm]/[kg/m <sup>3</sup> ]
1 HTM 22 A1		≥ 100	≥ 2 × 80 mm 10 mm cavity 100 mm cavity	10	- 80/10

\* arithmetically acc. Soundinsulationsoftware INSUL, Version v.8.0.3

\*\* based on EN 13501-2

Applied Load	Wall Weight	Sound Insulation $R_w$	Sound Insulation $D_{n,f,W}^{(12)}$	Fire Rating according EN 13501-2 (EN 1365-1)	Classification Report
[kN/m]	[kg/m <sup>2</sup> ]	[dB]	[dB]		
120 each wall side	≥ 143	$R_w \geq 55$ [-5;-12]* Pb.- Nr.: 04-01008  <hr/> $R_w \geq 75$ [-2;-6]* Pb.- Nr.: 04-01009	-	REI90	KB 3.2/16-279-3 -Covering: K <sub>2</sub> 10 -PC10069 -T <sub>max. 10 minutes</sub> : 112 °C
200 each wall side	≥ 185	$R_w \geq 60$ [-5;-13]* Pb.- Nr.: 04-01007  <hr/> $R_w \geq 74,5$ [-2;-4] Pb.- Nr.: 04-00961	-	REI90	KB 3.2/15-369-4 (Covering: K <sub>2</sub> 45)**
120 each wall side	≥ 100	$R_w \geq 57$ [-5;-12]* Pb.- Nr.: 04-01006  <hr/> $R_w \geq 77$ [-2;-6]* Pb.- Nr.: 04-01010	-	REI120	KB 3.2/15-369-3 (Covering: K <sub>2</sub> 30) -Covering: K <sub>2</sub> 30 -PCA10168 -T <sub>max. 30 minutes</sub> : 153 °C
150 each wall side	≥ 185	$R_w \geq 60$ [-6;-15]* Pb.- Nr.: 04-01003  <hr/> $R_w \geq 74,5$ [-2;-4] Pb.- Nr.: 04-00961	-	REI120	KB 3.2/15-369-4 (Covering: K <sub>2</sub> 45)**

Applied Load	Wall Weight	Sound Insulation $R_w$	Sound Insulation $D_{n,f,W}^{(12)}$	Fire Rating according EN 13501-2 (EN 1365-1)	Classification Report
[kN/m]	[kg/m <sup>2</sup> ]	[dB]	[dB]		
45 each wall side	≥ 97	$R_w \geq 49$ [-3;-9]* Pb.- Nr.: 04-01004  <hr/> $R_w \geq 69$ [-2;-15]* Pb.- Nr.: 04-01005	-	REI60	N° CSI1958FR -Covering: K <sub>2</sub> 10 -PCA10080 -T <sub>max. 10 minutes</sub> : 135 °C

# 1. Wall

## 1.1 CLT/X-LAM

### fermacell® - firewall

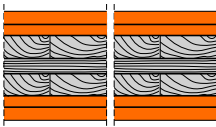
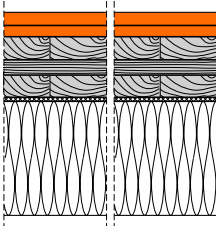
System Specification	Systemdrawing	Wall Thickness	CLT / X-LAM	Facings	Insulation Thickness/Density
		[mm]	[mm]	[mm]	[mm]/[kg/m <sup>3</sup> ]
4 HTM 32		≥ 146	≥ 80	15+ 18	-
4 HTM 33		≥ 280	≥ 80	innen 15+ 18 außen 160 mm STEICOprotect L dry + 6 mm STEICOsecure base	-

\*arithmetically acc. EN12354-1:2000, S. 28

### fermacell® - cavity firewall

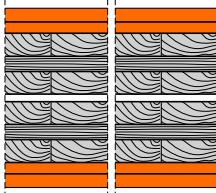
System Specification	Systemdrawing	Wall Thickness	CLT / X-LAM	Facings	Insulation Thickness/Density
		[mm]	[mm]	[mm]	[mm]/[kg/m <sup>3</sup> ]
4 HTM 31		≥ 236	≥ 2 × 80 mm 10 mm cavity 100 mm cavity	18+ 15	- <hr/> 80/18

\*arithmetically acc. Soundinsulationsoftware INSUL, Version v.8.0.3





Applied Load max. Stress sc,0,d,R90	Wall Weight	Sound Insulation $R_w$	Sound Insulation $D_{n,f,W}^{(12)}$	Fire Rating according EN 13501-2 (EN 1365-1)	Classification Report
[N/mm <sup>2</sup> ]	[kg/m <sup>2</sup> ]	[dB]	[dB]		
3,0	≥ 117	$R_w \geq 42$ [-1;-2] Pb.- Nr.: 04-01002	≥ 61	REI 90-M	KB 3.2/16-325-1 -Covering: K <sub>2</sub> 60 -PC10082 -T <sub>max. 60 minutes</sub> : 104 °C
2,5	≥ 123	$R_w \geq 36$ [-1;-5] Pb.- Nr.: 04-00879	≥ 61	REI 90-M	KB 3.2/15-222-2 (Covering from inside: K <sub>2</sub> 60) -Covering: K <sub>2</sub> 60 -PC10082 -T <sub>max. 60 minutes</sub> : 104 °C

Applied Load max. Stress sc,0,d,R90	Wall Weight	Sound Insulation $R_w$	Sound Insulation $D_{n,f,W}^{(12)}$	Fire Rating according EN 13501-2 (EN 1365-1)	Classification Report
[N/mm <sup>2</sup> ]	[kg/m <sup>2</sup> ]	[dB]	[dB]		
3 each wall side	≥ 152	$R_w \geq 56$ [-5;-13]*  $R_w \geq 74,5$ [-2;-4] Pb.- Nr.: 04-00961	-	REI 90-M	KB 3.2/16-325-1 (Covering: K <sub>2</sub> 60) -Covering: K <sub>2</sub> 60 -PC10082 -T <sub>max. 60 minutes</sub> : 104 °C

## 2. Covering

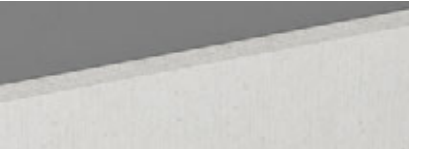

### 2.1 Classification of wall and ceiling coverings for fire protection ability

fermacell®

Coverings designated EN 13501-2	K <sub>2</sub> 10	K <sub>2</sub> 30
Facings	10mm	2×10 alternative 18mm
		
	<b>Classification Report</b> PC 10069	<b>Classification Report</b> KB III/B-07-059
		
		<b>Classification Report</b> PCA10168
Flooring **	-	-

\* based on EN 13501-2

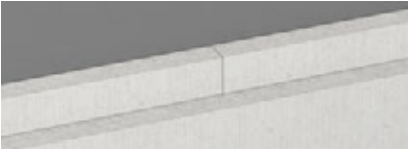
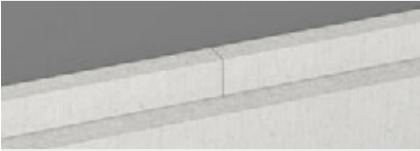
\*\* based on German building regulation

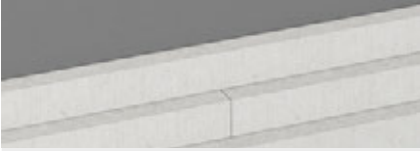
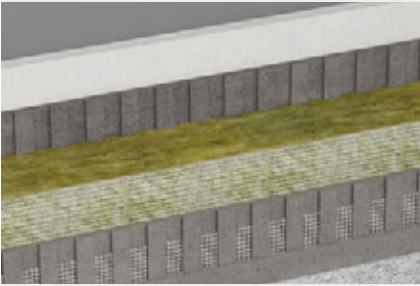
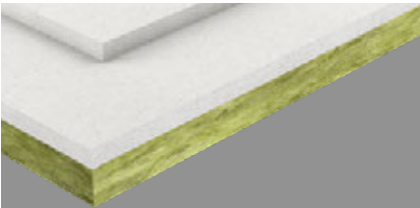
K <sub>2</sub> 45*	K <sub>2</sub> 60
2 × 15	15 + 18 mm alternative 2 × 18 mm alternative 3 × 12,5 mm alternative 12,5 mm + 60 mm ETICS (StoTherm Classic L)
 <p><b>Test Report</b> PB III/B-03-271</p>	 <p><b>Classification Report</b> PCA 10081</p>
	 <p><b>Classification Report</b> PCA 10% &amp;</p>  <p><b>Classification Report</b> PCA 10107</p>  <p><b>Classification Report</b> PCA 10% %</p>
	<p>2 E 35 fermacell® Flooring Element 2 × 12,5 mm fermacell® Gypsum Fibreboard + 20 mm mineral wool</p> 

A covering designated K2 is an encapsulation performance which for the classification period (10 min, 30 min or 60 min) provides the prescribed protection for the materials behind the covering.

During this time the mean temperature measured on the unexposed side of the covering not exceed the initial temperature by more than 250 K and the maximum temperature measured at any point of these sides not exceed the initial temperature by more than 270 K.

The classification protect the unexposed side of the covering against charring/burning during the time of classification.

*(see also EN13501-2)*

### 1 HTM 41

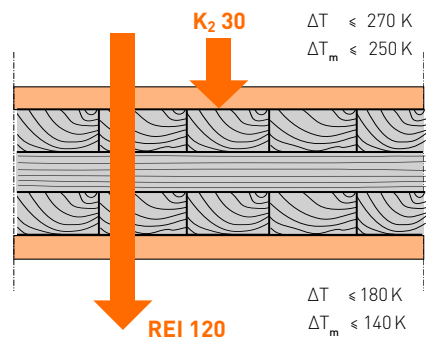

### 4 HTM 32

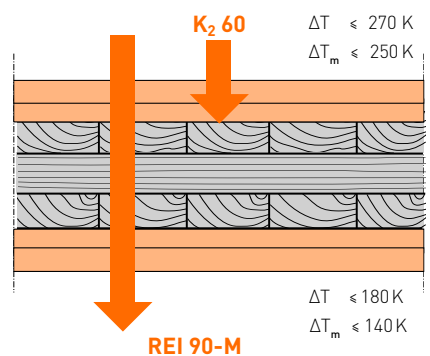

# 3. Ceiling

## 3.1 CLT/X-LAM

### fermacell® Flooring Elements



#### CLT/X-LAM

**REI 60 (b→a)\*\*** **REI 90 (b→a)\*\***  
*CLT 140 C5s* *CLT 160 C5s\**  
*Load: 5 kN/m<sup>2</sup>* *Load: 6 kN/m<sup>2</sup>*  
*Span: 5 m* *Span: 5 m*



Bare floor  
 $R_w = 39$  dB  
 $L_{n,w} = 85$  dB

System drawing	Construction	Constr. height	Sound insulation		Area of application
			Impact $L_{n,w}$	Airborne $R_w$	
			( $C_{t,100-2500}$   $C_{t,50-2500}$ )	( $C_{t,100-3150}$   $C_{t,r,100-3150}$ ) ( $C_{t,50-3150}$   $C_{t,r,50-2500}$ )	
			[mm]	[dB]	[dB]
	<b>2 E 22</b> (2 × 12,5 mm fermacell® Gypsum Fibreboards) on 30 mm fermacell™ Honeycomb Insulation on 20 mm Floorrock GP on 60 mm EPS 150 kPa on 30 mm fermacell™ Honeycomb Insulation	305	<b>46,0</b> <b>(+2   +8)</b>	67,8 [-4   -12 -9   -21]	1
	<b>2 E 22</b> (2 × 12,5 mm fermacell® Gypsum Fibreboards) on 30 mm fermacell™ Honeycomb Insulation onf 80 mm Schneider 140 kPa on 30 mm fermacell™ Honeycomb Insulation	305	<b>48,4</b> <b>(+1   +5)</b>	68,3 [-4   -11 -9   -22]	1
	<b>2 E 35</b> (2 × 12,5 mm fermacell® Gypsum Fibreboards + 20 mm Mineral Wool) on 2 × 30 mm fermacell™ Honeycomb Insulation	245	<b>50,2</b> <b>(+0   +3)</b>	66,9 [-3   -10 -8   -20]	1
	<b>2 E 35</b> (2 × 12,5 mm fermacell® Gypsum Fibreboards + 20 mm Mineral Wool) on 30 mm fermacell™ Honeycomb Insulation	215	<b>51,8</b> <b>(+1   +4)</b>	64,2 [-4   -11 -9   -20]	1
	<b>2 E 22</b> (2 × 12,5 mm fermacell® Gypsum Fibreboards on 20 mm Steico Therm sd on 30 mm fermacell™ Honeycomb Insulation	215	<b>53,6</b> <b>(+1   +3)</b>	64,1 [-4   -11 -9   -20]	1

\*\*ETA-14/0349

## fermacell® Flooring Elements



CLT/X-LAM  
suspended ceiling



Bare floor  
No ascertainable  
output value

System drawing	Construction	Constr. height	Sound insulation		Area of application
			Impact $L_{n,w}$ ( $C_{t,100-2500}$   $C_{t,50-2500}$ )	Airborne $R_w$ ( $C_{100-3150}$   $C_{t,r,100-3150}$ $C_{50-3150}$   $C_{t,r,50-2500}$ )	
		[mm]	[dB]	[dB]	
	<p><b>2 E 35</b> [2 × 12,5 mm fermacell® Gypsum Fibreboards + 20 mm Mineral Wool] on 2 × 30 mm fermacell™ Honeycomb Insulation with 140 mm CLT with 27 mm flexibly suspended + Mineral Wool on 3 × 12,5 mm fermacell® Gypsum Fibreboards</p>	309,5	<b>38,7</b> <b>(+2   +21)</b>	75,8 [-7   -16 -22   -35]	1
	<p><b>2 E 35</b> [2 × 12,5 mm fermacell® Gypsum Fibreboards + 20 mm Mineral Wool] on 2 × 30 mm fermacell™ Honeycomb Insulation with 140 mm CLT with 27 mm flexibly suspended + Mineral Wool on 2 × 12,5 mm fermacell® Gypsum Fibreboards</p>	297	<b>41,3</b> <b>(+2   +18)</b>	74,2 [-9   -18 -21   -34]	1
	<p><b>2 E 35</b> [2 × 12,5 mm fermacell® Gypsum Fibreboards + 20 mm Mineral Wool] on 2 × 30 mm fermacell™ Honeycomb Insulation with 140 mm CLT with 27 mm flexibly suspended + Mineral Wool on 2 × 12,5 mm fermacell® Gypsum Fibreboards</p>	284,5	<b>50,0</b> <b>(+4   +10)*</b>	74,2 [-9   -18 -21   -34]*	1

\* internal review and investigation

You will find the latest version of this brochure in digital form on our website. Technical modifications subject to changes. Last updated 02/2021

The most recent edition applies. Should you require additional information, please contact our customer service.

©2021 James Hardie Europe GmbH.

™ and ® denote registered and unregistered trademarks of James Hardie Technology Ltd. and James Hardie Europe GmbH.

**James Hardie Europe GmbH**

Bennigsen-Platz 1  
D-40474 Düsseldorf  
www.fermacell.com

**Technical customer information (freecall)**

phone 08003864001  
e-Mail [fermacell@jameshardie.de](mailto:fermacell@jameshardie.de)

**Service-Center (order management)**

phone +49 211 54236-200  
fax +49 211 54236-299  
e-mail [auftraege@jameshardie.com](mailto:auftraege@jameshardie.com)

fer-600-00011/02.2021

